

***THE TNT HR-X  
REFERENCE TURNTABLE &  
TONEARM***



***SETUP AND INSTRUCTION  
MANUAL***

VPI INDUSTRIES INC., 77 CLIFFWOOD AVE #3B, CLIFFWOOD N.J. 07721  
PHONE: 732-583-6895, FAX: 732-946-8578  
[www.vpiindustries.com](http://www.vpiindustries.com)

## HOW TO SET UP YOUR HR-X

- **The most important thing you can do for your new HR-X is to place it on a level surface. It cannot be stressed enough that a level base for the HR-X will make set up much easier.**
- **It is best to place the HR-X on a level surface that measures at least 34 x 21 inches. This will allow room for the optional dust cover if you should want to purchase it.**
- Open the box labeled PART B. Remove the foam or cardboard and you will find the Motor Drive Unit or MDU and the platter. Carefully place the MDU in a safe location. Under the round foam cutout is the platter. Remove it and place it in a safe location. Below this is the ring clamp.
- In the box labeled PART A, you will find the main HR-X chassis with the JMW-12A mounted. The tonearm wand should be removed with all the loose parts (alignment jig, hardware, record clamp, etc.) and placed on the side. You can now move the chassis with the air suspension and tonearm base attached.

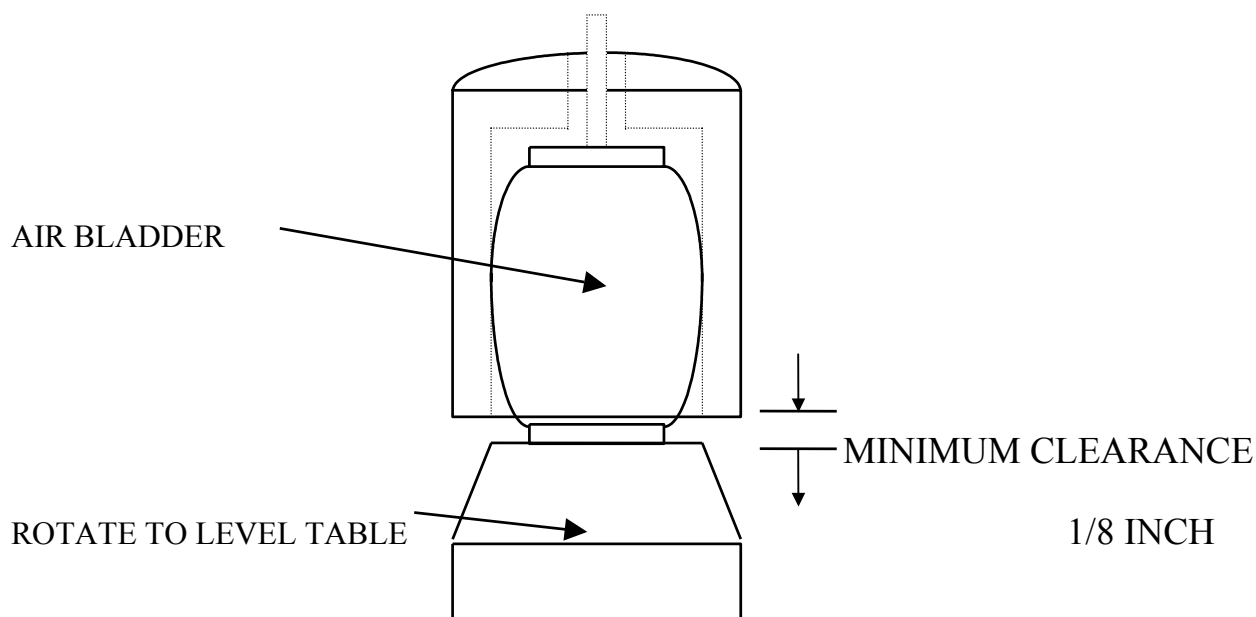

- You now have the Main Chassis sitting on the 4 feet. This is a good time to make sure that the table is positioned correctly. If it must be moved slightly or centered on its stand, do it slowly.
- Place the platter on the spindle. Put a drop of oil on the spindle shaft and two drops down the hole of the platter. Carefully lower the platter down onto the spindle. Spin the platter and check that it is spinning freely and that there is no wobble.
- It is very important that HR-X is level. Place a 12" long bubble level across the platter and level the turntable in two directions, left to right and front to back. Rotating the black cone shaped feet on the bottom of the four legs will level the unit. You must hold the bladders when doing this.
- Now place the MOTOR/FLYWHEEL ASSEMBLY (MFA) in position. The left side of the HR-X has a cutout where the MFA positioned. The MFA is heavy and should be moved slowly. Leave at least 1/8" clearance between the chassis and the MFA. The power button goes to the left, the socket to the rear.

**NEVER TURN THE MFA OVER, THE FLYWHEEL CAN FALL OUT AND GET DAMAGED OR HURT YOU.**

- If the belt does not run level between the platter and the flywheel, readjust the corner leveling legs. If you turn them all one turn at a time, you will not change the level of the HR-X, but you will move the entire unit up and down. This is not super critical but do your best.
- 
- Be very careful when handling the tone arm. The internal arm wire is exposed at the headshell and at the rear of the arm. This wire is *very* delicate and contains 64 strands of very pure copper. Physical damage to the wire is not covered by the warranty after the arm is removed from its box.
  - Please do not touch the unipivot bearing parts. Finger oils on the bearing cup in the upper bearing housing or on the lower pivot point in the arm base assembly can cause blemishing of the bearing and possible corrosion. Also, the point is sharp, be careful.
  - There are a number of setscrews on the JMW Memorial Tone Arm. The Allen wrench that comes with your arm will only fit the setscrews that you will need to adjust. All other screws are factory set and should not be adjusted, except by our trained technicians. Resetting any of the factory settings is not covered by the warranty.

## ***SETTING YOUR JMW MEMORIAL TONE ARM***

- You will see a number of things in plastic bags:
  - Allen wrenches
  - Hex nuts, and washers (for cartridge mounting)
  - Arm mounting and alignment tool
  - Shure stylus gauge
- Take all these items out and set them aside. Be careful with the damping fluid. It should be kept sealed until it is used.

### **A. CARTRIDGE MOUNTING:**

- Remove the arm tube from the box (taking special care not to strain or damage, the delicate 4-color wire and Lemo connector) and place it right side up on the foam pad.

#### **FOR CARTRIDGES WITH THREADED MOUNTING HOLES:**

- Use the screws supplied by the cartridge manufacturer to mount the cartridge. Any other screws may not fit the thread properly and may even damage the threads and cartridge. **USE ONE OF THE SUPPLIED WASHERS UNDER THE SCREW HEAD.**
- For all cartridges with pass through mounting holes use the hardware supplied with the arm. Remember to use the washers under the screw heads to prevent damage to the finish on the JMW arm.
- In this step, the connectors will be attached to the cartridge's terminals. Disregard the color of the insulators on the cartridge clips.

#### **THE COLOR CODE OF THE WIRES IS AS FOLLOWS:**

RED = right hot  
GREEN = right ground

WHITE = left hot  
BLUE = left ground

**IF YOUR PHONO SECTION INVERTS PHASE, THE HOT BECOMES  
THE GROUND COLOR**

- The arm tube should be on its side on the foam pad when doing this.

- Using tweezers or fine tipped pliers, grip the center of the red wire's connector (do not grip the wire) and push it onto the cartridge's right hot terminal pin. In the same way, connect each of the remaining connectors to its respective cartridge terminal. Do not push the connectors all the way on, as this could damage the cartridge. Always back up the cartridge with your finger when pushing on the clips.
- At the rear of the arm base assembly is the connector block. Plug the Lemo connector into its receptacle on top of the block. Notice that the connector can plug in only one way. Align the red dots on the arms plug with the red dot on the receptacle. Push gently, do not force the plug.

## B. THE COUNTERWEIGHT:

- The JMW 12.6 tone arm comes with one large counterweight installed on the rear shaft of the tonearm. For most cartridges you will only need this large weight. The counterweight is held in position by a setscrew.
- The counterweight is used for setting the azimuth (lateral balance) of the cartridge and the vertical tracking force.
- For now, position the large counterweight to give a minimum of tracking force, just enough force to keep the cartridge on the alignment jig.
- In some rare cases it may be necessary to use two counterweights together. Contact your dealer if a second counterweight is needed.

## C. OVERHANG ADJUSTMENT & ALIGNMENT

- This adjustment will yield the lowest overall distortion when playing a typical 12" record. Do not go crazy over this adjustment. You do not know if the stylus is aligned properly on the cantilever. You are also facing a constantly moving target when playing a record. The arm is moving in 3-dimensions and will only approximate the accuracy you have built into your alignment.
- Place the Alignment Jig into position by sliding the narrow end with the circular cutout between the arms lateral balance weight and the platform that supports the armrest. Make sure that the jig's cutout fits against and around the bearing well.

- While holding the one end against the bearing well, swing the other end (with the hole) over the turntable's spindle so that the spindle holds the jig in place.
- While the arm is in its rest, loosen the screws that hold the cartridge just enough that the cartridge can be moved back and forth.
- Carefully swing the arm over the grid at the far end of the jig and place the stylus as close to the dot in the center of the grid as possible. Using a lighted magnifier will make this job very easy.

**BE VERY CAREFUL NOT TO DAMAGE THE CARTRIDGE STYLUS:**

- Move the cartridge so that the stylus rests on the dot. Now, viewing the cartridge from above, line it up so that its sides are symmetrically positioned between the lines of the grid. If the cartridge has parallel sides, these should be made parallel to the grid lines. Also make sure that the cartridge is centered between the sets of lines. Follow figure 3 in the back of the manual.

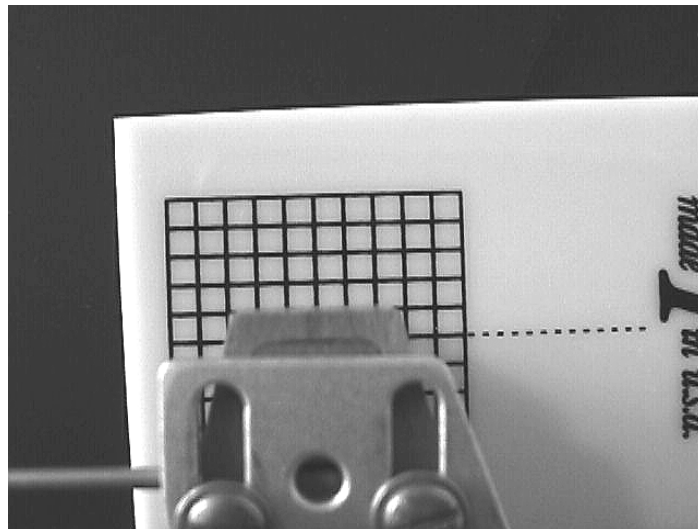

- Double check the adjustments made above. The cartridge needs to be both centered and "square" between the grid lines and have the stylus resting on the dot.
- The alignment gauge does not have a hole or dimple to hold the stylus. While the printed dot makes it harder to keep the stylus in place, this method was chosen to avoid the possibility of damaging the stylus cantilever or the diamond tip as the cartridge is positioned.
- Place the arm back in its rest.

- Without letting the cartridge move, tighten the screws holding the cartridge to the arm head. Make it tight, but don't over do it and strip the threads or distort the cartridge body.

#### D. TRACKING FORCE:

- Tracking force is adjusted by moving the counterweight forward and back a bit at a time. At least initially, you will be setting the tracking force twice. The first time will be before the cartridge's overhang is set. After this is done, you will need to double check the tracking force and adjust it as needed.
- The JMW 12.6 does not have a built-in tracking force gauge, but a Shure Stylus Force Gauge is supplied with your unit. Following the gauge instructions set the tracking force to the cartridge manufacturer recommendation plus 1/10 of a gram more. We always recommend going to the high side when it comes to tracking force. High frequency vibrations can make a light tracking cartridge to cause more damage to the grooves than running a cartridge at a heavy setting.

#### E. AZIMUTH

- Next, the lateral balance or azimuth must be set. Because the phono cartridge is offset, there is an unbalancing force that tilts the arm to one side. For the cartridge to properly track the record groove, the stylus must be ninety degrees to the record surface. Move the counterweight so a slight tracking force is applied and the stylus just sits on the record surface.
- By rotating the counterweight you can tip the arm in either direction. Set the counterweight so the cartridge sits as shown below.



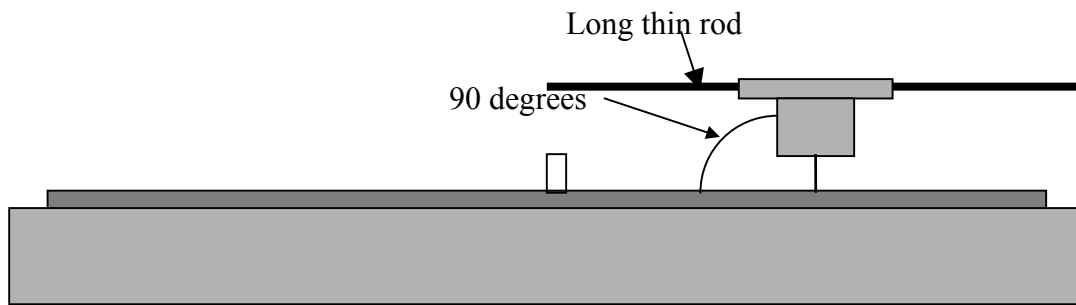

## E. ANTI-SKATING:

- A pivoted arm without an offset head would not be subject to skating force. However, it will also have no correction for tracking error and the resulting distortion is unacceptable. As soon as the arm's head is offset to lower tracing distortion, skating force arises. Greater offsets result in greater skating force. The 12" arm has a very small offset angle and therefore a very low skating force to deal with.
- After very careful listening tests we have determined that every tonearm we tried sounded better with their mechanical anti-skating disabled and the tracking force very slightly increased. All mechanical anti-skate devices add a negative sound to the music because they are made of parts that can vibrate. We solve the problem in a unique way:
- As mentioned earlier, the arm wire applies the anti-skating force. The degree of force applied can be adjusted as explained below.
- To increase or decrease the amount of anti-skating force applied, simply unplug the Lemo connector and twist it in the direction you want the force applied.
- For example, to increase anti-skating force give the connector a counterclockwise twist, unwinding the coiled wire. Likewise, to decrease the force, give the connector a clockwise twist. Remember, the Lemo connector can only be "adjusted" in increments of whole turns. If it is not, its key will not line up with the groove in the receptacle.
- We could go on discussing the pros and cons of how much anti-skate is correct, but the sonic answer is very simple. Adjust the wire as mentioned above until the tonearm drifts outward when set to neutral balance. When you push the neutral balance floating tonearm towards the center of the record, it should push

back out towards the rim of the record. Very little force is needed to do this, and the wire acts like a spring to supply this force.

- **If you try adjusting the anti-skate with a groove less record or a test record you will ruin the twist in the wire and void your warrantee**
- Double check the horizontal balance, lateral balance, and tracking force and adjust as needed. Increase the tracking force by 1/10 of a gram above the cartridge manufacturers highest recommended force.

## G. ARM HEIGHT:

**NOTE: THE TWO THUMBSCREWS MUST BE RELEASED WHEN MOVING THE VTA KNOB. THE THUMBSCREWS SHOULD BE TIGHTENED WHEN LISTENING.**

Unlike many tone arms, the JMW's height is both easy and repeatable to vary. The knob next to the bearing housing bears a scale numbered from zero to ninety-nine. Below the knob there is an index mark engraved on the front of the support pillar.

Rotating the knob clockwise lowers the arm and rotating it counterclockwise raises it.

Set the arm height as follows:

- Place a record on the platter surface. Lower the arm onto the record and make the arm tube parallel to the record surface by rotating the arm-height knob as needed.
- This is a good initial setting. You may wish to vary it depending on the cartridge you are using and or the particular record being played. The knob's scale makes it easy to return to a previous setting by making a note of the number above the index mark and the number of complete turns taken.
- The old wisdom, which had the arm tube parallel to the record surface, assumed not only that all cartridges had the same internal geometry and stylus rake angle but also that all records were cut with the same equipment set the same way. The idea was that everything would line up properly with the arm parallel to the record. This is not true and the VTA should be adjusted for best sound in your system.
- **Rule of thumb: Raising VTA lowers bass and increases treble. Lowering VTA increases bass and decreases treble.**

## H. CONNECTING TO THE PREAMPLIFIER/AMPLIFIER

- ONLY USE INTERCONNECTS THAT ARE SHIELDED AND PROPERLY GROUNDED. NON-SHIELDED INTERCONNECTS CAN HUM AND PICK UP RF.
- The connector block at the rear of the arm base has, in addition to the Lemo receptacles two phono receptacles and a ground connector.
- Plug one end of the output cable into the phono jacks. The jack with the red ring is the right channel and the jack with the black or white ring is the left.
- Plug the other end of the cable into the turntable inputs on your pre-amplifier, preamplifier, or integrated amplifier as appropriate.
- The ground connection is available to eliminate hum if necessary. If hum is present, first connect a ground lead from the connector block to the preamplifier or amplifier to which the output cable is connected. If this does not eliminate the hum, run a ground wire from the turntable chassis to the connector block as well. The block's connector will accept bare wires, spade lugs, or ring tongue connectors.

## I. VERY IMPORTANT!!!

Do not run the HR-X for days at a time to break it in. The flywheel runs on a Teflon thrust disc and continuous running will damage this disc. The table will be broken in after three to four records. Turn the HR-X on 20 minutes before listening to loosen everything up and warm up the drive belts

SET SCREW

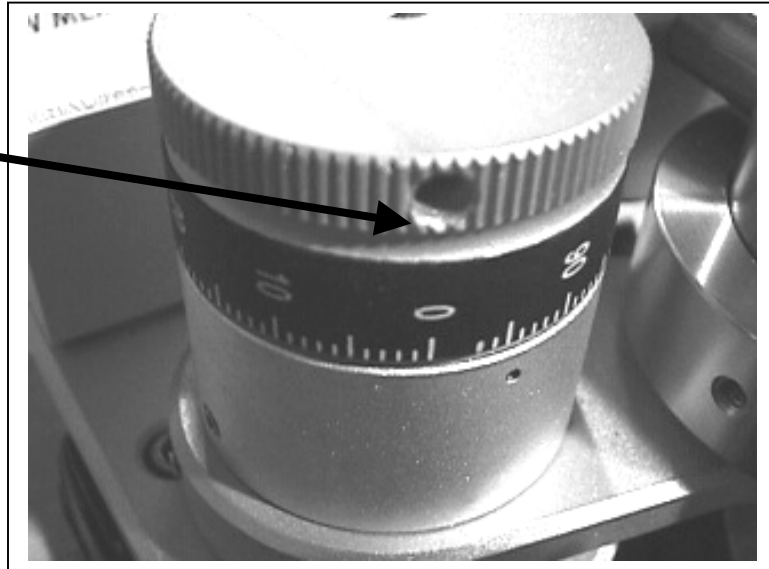

IF THE VTA KNOB SHOULD EVER LOOSEN UP, BACK OFF THE SET SCREW SHOWN, PUSH DOWN ON THE KNOB AND RETIGHTEN THE SET SCREW.

- There is very little maintenance associated with the HR-X. Every 3 months put a drop of bearing oil (supplied) on your finger and touch the belts while they are running. Use very little oil. Do not put oil on the flywheel to platter belt.
- The bottle of light oil is used to occasionally lubricate the motors and flywheel. If either unit ever makes noise, it is time to re-lube it.
- There is a break-in period of at least 30 hours before the HR-X will sound the best. For best possible sound try to turn on the turntable at least 20 minutes before you do serious listening. This will loosen up the belts, and warm up the lubricant in the bearings.

## PLAYING A RECORD

- Place the record on the platter and drop on the record spindle weight. No washer is used under the record in this system. Take the ring clamp and lower it onto the record rim keeping it level all around. The lip of the clamp grabs the top of the record rim while the inside of the clamp slides down the rim of the platter. If done properly, you will get the effect of vacuum with none of the problems or complications. Remember to slide the ring clamp down uniformly all around the record rim.
- **Be careful to keep the stylus away from the ring clamp. There is plenty of room if you are not careless.**
- It is normal for the motor to make some low-level noise. None of this gets into the system. The more you use your HR-X, the quieter the motor and the bearings will become.
- **You must mail in your warrantee card.** If your card is not received within 30 days of purchase, you are jeopardizing your warrantee. The motor and bearings of the HR-X are warranted for 5 years. There is nothing else that can fail on your HR-X except the belts, which should be changed every year.

## DETAILS ON AIR SUSPENSIONS

- The HR-X uses pneumatic Micro-actuators in the four suspension towers. These actuators come with 20 pounds air pressure from the factory.
- The best way to add air is to get a tank from Home Depot (approx. \$30.00) with a regulator set for 20 pounds. Fill the tank with 60 pounds of air and when you need air in the bladders use the tank to refill the bladders. With this system the bladders fill instantly and there is no noise.
- You can lower the pressure for a lower resonant frequency and greater isolation by unscrewing the silver caps and touching the needle in the center of the valve with a pen point. Never lower the air pressure to less than 1/8<sup>th</sup> inch clearance between the stainless steel tower and the black cone shaped foot.