

***THE TNT-5 AIR  
REFERENCE TURNTABLE***



***SETUP AND INSTRUCTION  
MANUAL***

VPI INDUSTRIES INC., 77 CLIFFWOOD AVE #3B, CLIFFWOOD N.J. 07721

PHONE: 732-583-6895, FAX: 732-946-8578

[www.vpiindustries.com](http://www.vpiindustries.com)

## HOW TO SET UP YOUR TNT 5

- **The most important thing you can do for your new TNT 5 is to place it on a level surface. It cannot be stressed enough that a level base for the TNT will make set up much easier.**
- **It is best to place the TNT 5 on a level surface that measures at least 32 x 21 inches. This will allow room for the optional dust cover if you should want to purchase it.**
- Open the box labeled PART B and removing the foam, you will find the Motor Drive Unit or MDU. Be careful, this unit is heavy. Under the round foam cutout is the platter. Remove it and place it and the MDU in a safe location.
- In the box labeled PART A you will see the record clamp and below the foam the main TNT-5 chassis with air suspension. This is very heavy so be careful when lifting out the chassis. Place the chassis where it will be situated and make sure you do not bang the rubber air suspension bladders.

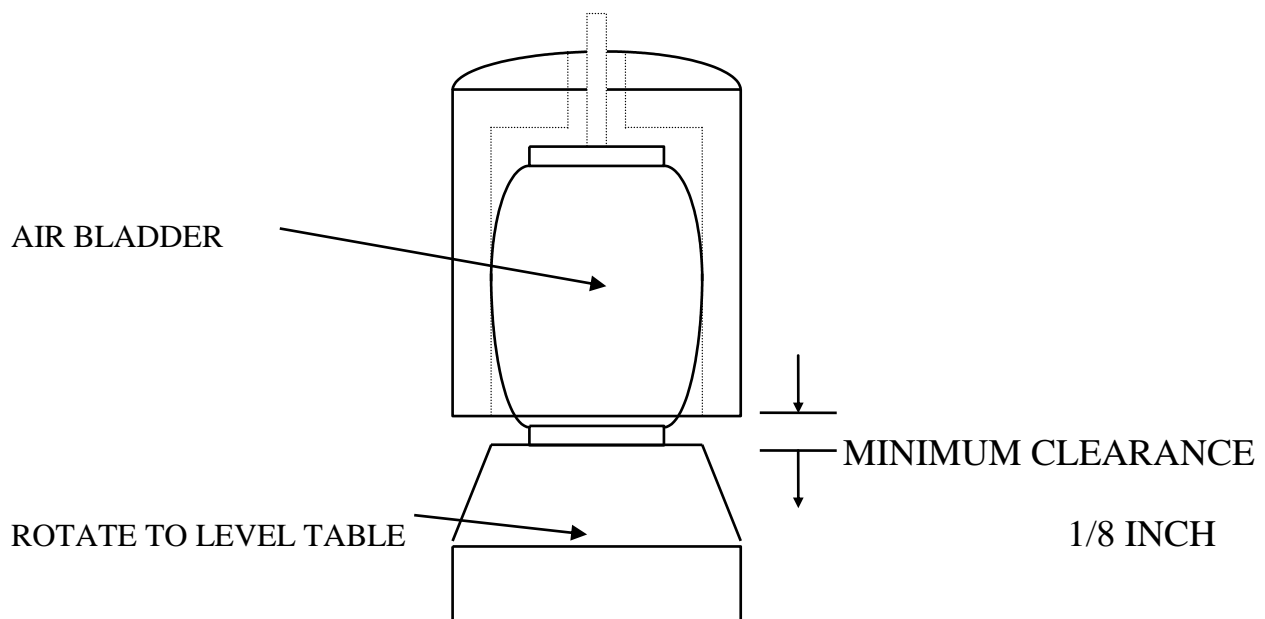

- You now have the Main Chassis sitting on the 4 feet. This is a good time to make sure that the table is positioned correctly. If it must be moved slightly or centered on its stand, do it slowly. Now, peel off the paper on the top of the main chassis. *We shipped the suspension with air installed. If you need to add air, use a bicycle pump.*
- You have the newest HR-X type platter and bearing assembly. Remove the tape covering the platter bearing and place the platter on the spindle. Carefully lower the platter down onto the spindle. Spin the platter and check that it is spinning freely and that there is no wobble.
- It is very important that the platter be level. Place a 12" long bubble level across the platter. Level the platter in two directions, 90 degrees apart. Rotating the black cone shaped feet on the bottom of the four legs will level the unit. You must hold the bladders when doing this.
- Now place the Flywheel in position. The left side of the TNT 5 has a cutout where the Flywheel will be centered. Place the motor in its proper location as shown in the “Proper Layout for Flywheel Usage” diagram. Make sure you have a level surface of at least 32 inches in length. VPI makes a custom extended top for the TNT stand to put the TNT-5 on.

### PROPER LAYOUT FOR FLYWHEEL USAGE

Distance between motor and flywheel, center to center = 140mm +/- 2mm

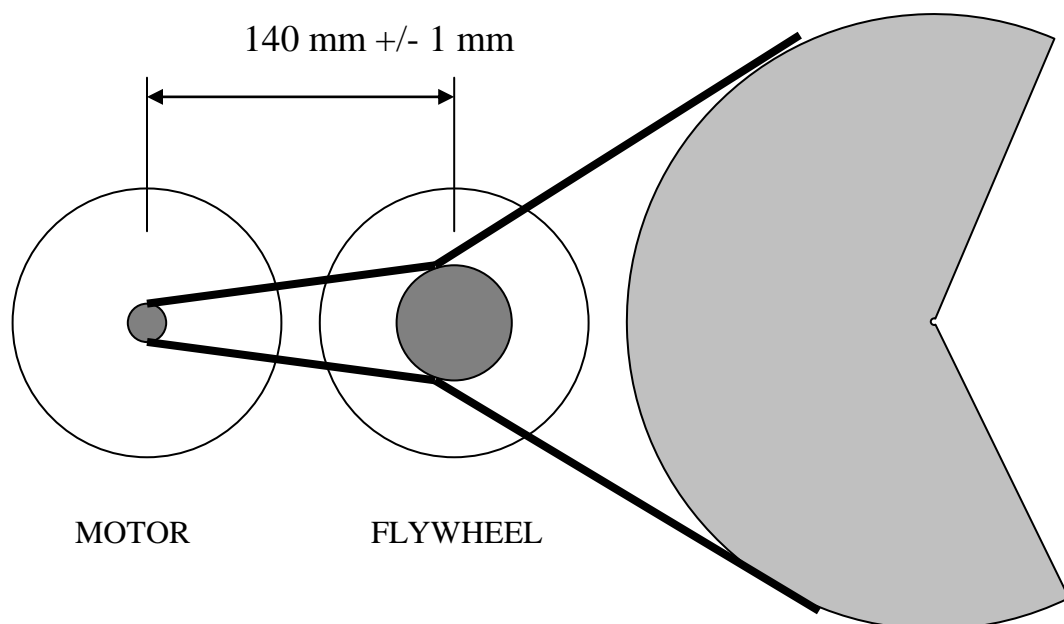

- There is very little maintenance associated with the TNT 5. Every 3 months re-powder the drive belt between the motor and flywheel by placing it in its' original bag. Shake off the excess powder and put them back in the same location on the pulleys.
- The bottle of light oil is used to occasionally lubricate the motor and flywheel. If either unit ever makes noise, it is time to re-lube it. Put one drop of oil on the motor shaft every six months. The Flywheel should be oiled every year. Put two drops on the spindle shaft and three drops down the spindle hole.
- Using the proper Allen wrench provided, unscrew the tonearm board from the Main Chassis. If you ordered your armboard pre-drilled, you can now install your tonearm following the manual supplied with it. If you are working with a blank board, you should follow the tonearm guide for the generic phrase, "installing your tonearm". Please use all safety measures when using power tools. If you are not familiar with the generally accepted methods of power tool safety, you should have your dealer drill the armboard, or send it back to VPI and we will do it.
- When the arm and cartridge are installed, recheck the turntable level.
- There is a break-in period of at least 30 hours before the TNT will sound its' best. For best possible sound try to turn on the turntable at least one hour before you do serious listening. This will stabilize and loosen up the belts, and warm up the lubricant in the bearings.
- When playing records, remember that the black washer goes on the platter first, then the record, and then the clamp. This system will force the air out from under the record and form a partial vacuum. When you release the clamp, the record does not pop back up. If done properly, you will get the effect of vacuum with none of the problems or complications.
- It is normal for the motor to make some low-level noise. None of this gets into the system. The more you use your TNT, the quieter the motor and the bearings will become.
- **You must mail in your warrantee card.** If your card is not received within 30 days of purchase, you are jeopardizing your warrantee. The motor and bearings of the TNT 5 are warranted for 5 years. There is nothing else that can fail on your TNT except the belts, which should be changed every year.

- Observing the way they run will help you set tension on the belts. The belts should not be flopping loosely. The belts between the motor and the flywheel should be tight enough that the belts run true and the platter reaches speed in roughly 10 seconds. Use the measurements in the diagram as a beginning.
- The belts between the motor and the flywheel should be powdered when new and every month. You can use baby powder or corn starch for this purpose. Make sure that the belts run relatively level from motor to flywheel and from flywheel to platter.

### **DETAILS ON AIR SUSPENSIONS**

- The TNT-5 uses pneumatic Micro-actuators in the four suspension towers. These actuators come with very little air pressure from the factory. When you add air, you should use a hand pump with a quick release valve. Fill them by hand with two quick bursts of pressure.
- You can lower the pressure for a lower resonant frequency and greater isolation by unscrewing the caps and touching the needle in the center of the valve with the tip of a Phillips screwdriver or Allen wrench. By carefully letting out air, you can set the level of the turntable without rotating the legs.
- Never lower the air pressure to less than 1/8<sup>th</sup> inch clearance between the stainless steel tower and the black cone shaped foot.
- Try to get the table as level as possible with the air suspension and then final level the TNT by rotating the bottom cone shaped foot.

**REMEMBER: THE HIGHER THE PRESSURE THE FASTER THE TABLE SOUNDS, THE LOWER THE PRESSURE THE WARMER THE TABLE SOUNDS. HIGHER PRESSURES WILL MAINTAIN LEVEL SETTING LONGER.**