

The JMW-9T Tonearm

Setup and Instruction Manual

VPI Industries, Inc., 77 Cliffwood Ave. #3B, Cliffwood, NJ 07721
Phone: 732-583-6895 Email: Sales@vpiindustries.com
<http://www.vpiindustries.com>

BEFORE YOU BEGIN

- Be very careful when handling the tone arm. The internal arm wire is exposed at the headshell and at the rear of the arm. The wire is very delicate and physical damage to the wire is not covered by the warranty after the arm is removed from its box.
- When you remove the black tube covering the unipivot male bearing assembly be very careful it is sharp, do not touch it, you will get punctured or cut.
- There are a number of setscrews on the JMW-9T, the Allen wrenches that come with your arm will only fit the setscrews that you will need to adjust. All other screws are factory set and should not be adjusted, except by our trained technicians. Resetting any of the factory settings is not covered by the warranty.

A. CARTRIDGE MOUNTING:

FOR CARTRIDGES WITH THREADED MOUNTING HOLES:

- Use the screws supplied by the cartridge manufacturer to mount the cartridge. Any other screws may not fit the thread properly and may even damage the threads and cartridge. **USE ONE OF THE SUPPLIED WASHERS UNDER THE SCREW HEAD.**
- For all cartridges with pass through mounting holes use the hardware supplied with the arm. Remember to use the washers under the screw heads to prevent damage to the finish on the JMW arm. In this step, the connectors will be attached to the cartridge's terminals. Disregard the color of the insulators on the cartridge clips.

THE COLOR CODE OF THE WIRE IS:

RED = right hot
GREEN = right ground

BLACK OR WHITE = left hot
BLUE = left ground

IF YOUR PHONO SECTION INVERTS PHASE, THE HOT COLOR BECOMES THE GROUND COLOR

- Using tweezers or fine tipped pliers grip the center of the red wire's connector (do not grip the wire) and push it onto the cartridge's right hot terminal pin. In the same way, connect each of the remaining connectors to its respective cartridge terminal. Do not push the connectors all the way on, as this could damage the cartridge. Always back up the cartridge with your finger when pushing on the clips.
- The 9T tonearm comes with one dropped counterweight installed on the rear shaft of the tonearm. For most cartridges you will only need this large weight. The counterweight is held in position by a setscrew.
- Pick up the arm tube, taking care not to strain or damage the fine 4-color wire and Lemo connector.
- For now, position the large counterweight as close to the bearing housing as you can (toward the front of the arm) but not touching the balance ring. The object here is to balance the arm while keeping the counterweight as close to the bearing housing as possible. This results in the least inertia for a given cartridge weight.

- In some rare cases it may be necessary to use two counterweights together or a larger counterweight. Contact your dealer if a second or larger counterweight is needed.

B. OVERHANG ADJUSTMENT:

- This adjustment will yield the lowest distortion in the last third of the record, the hardest to track, when playing a typical 12" record. Do not go crazy over this adjustment. You do not know if the stylus is aligned properly on the cantilever. You are also facing a constantly moving target when playing a record. The arm is moving in 3-dimensions and will only approximate the accuracy you have built into your alignment.
- Place the arm tube assembly on the lower bearing, taking care not to strain or damage the 4-color wire and Lemo connector. Place the arm in its rest.
- At the rear of the arm base assembly is the connector block. Plug the Lemo connector into its receptacle on top of the block. Notice that the connector can plug in only one way. Align the red dots on the arms plug with the red dot on the receptacle. Push gently, do not force the plug.
- Place the Alignment Jig into position by sliding the narrow end with the circular cutout between the arms lateral balance weight and the platform that supports the armrest. Make sure that the jig's cutout fits against and around the bearing well and the hole is over the spindle.
- While the arm is in its rest, loosen the screws that hold the cartridge just enough that the cartridge can be moved back and forth.



- Carefully swing the arm over the grid at the far end of the jig and place the stylus as close to the dot in the center of the grid as possible. Using a lighted magnifier glasses will make this job very easy.
- **BE VERY CAREFUL NOT TO DAMAGE THE CARTRIDGE'S STYLUS:**
- Move the cartridge so that the stylus rests on the dot. Now, viewing the cartridge from above, line it up so that its sides are symmetrically positioned between the lines of the grid. If the cartridge has parallel sides, these should be made parallel to the grid lines. Also make sure that the cartridge is centered between sets

of lines. If you can see the cantilever clearly you can align the cantilever to the alignment grid. This is difficult and may produce no increase in sound quality.

- Double check the adjustments made above. The cartridge needs to be both centered and "square" between the grid lines and have the stylus resting on the dot.
- Place the arm back in its rest.
- Without letting the cartridge move, tighten the screws holding the cartridge to the arm head. Make it tight, but don't over do it and strip the threads or distort the cartridge body.

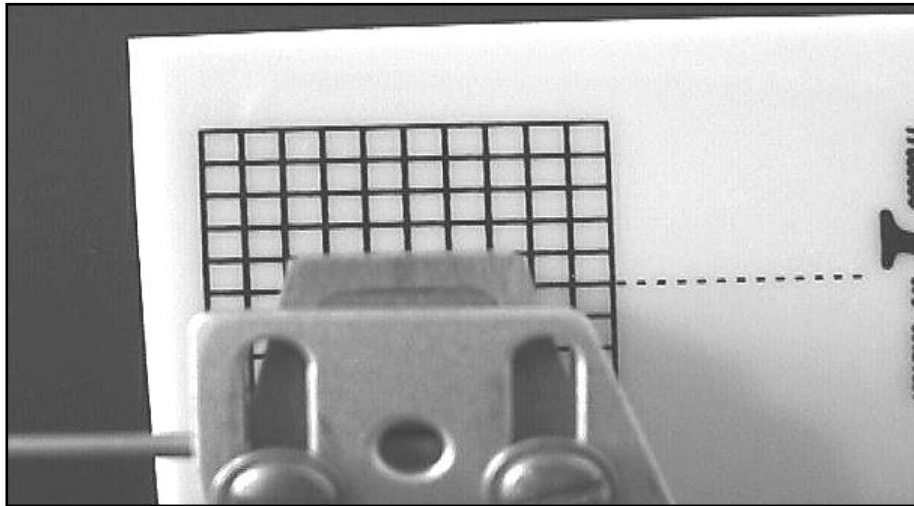

FIG #2: THE PROPER WAY TO ALIGN A CARTRIDGE, ALIGN THE CARTRIDGE, NOT THE TONEARM HEADSHELL! SHOWN IN WHITE FOR CLARITY.

C. TRACKING FORCE AND AZIMUTH

- Place the arm tube assembly on the lower bearing, taking care not to strain or damage the 4-color wire and Lemo connector. Place the arm in its rest.
- Make sure the turntable is level. Refer to your turntable instructions and use a bubble level to check level. In most cases, the best place to put the level is on the platter.
- With a unipivot arm it is particularly important to level the turntable.
- Move the counterweight until the arm has a very slight downward tracking force, just enough to keep it from moving sideways on the platter or enough to keep it in the groove of the record
- Tracking force is adjusted by moving the counterweight forward and back just a bit at a time. At least initially, you will be setting the tracking force twice. The first time will be before the cartridge's overhang is set. After this is done, you will need to double check the tracking force and adjust it as needed.
- The JMW-9T does not have a built-in tracking force gauge, but a Shure Stylus Force Gauge is supplied with your arm on a new unit. Following the gauge instructions set the tracking force to the cartridge manufacturer recommendation plus 1/10 of a gram more. We always recommend going to the high side when it comes to tracking force. High frequency vibrations can cause a light-tracking cartridge to cause

more damage to the grooves than running a cartridge at a heavy setting. Make sure the damping fluid is not installed when setting this force.

VERY IMPORTANT: MAKE SURE THE TONEARM IS PARALLEL TO THE PLATTER WHEN SETTING THE TRACKING FORCE. IF IT IS NOT THE END RESULT WILL BE HIGHER OR LOWER VTF THAN YOU WANTED.

- Next, the lateral balance or azimuth must be set. Because the phono cartridge is offset, there is an unbalancing force that tilts the arm to one side. For the cartridge to properly track the record groove, the stylus must be ninety degrees to the record surface. Move the counterweight so a slight tracking force is applied and the stylus just sits on the record surface.
- Use the azimuth ring to set correct azimuth. Lay the long thin rod supplied behind the cartridge mounting screws into the V groove and use it as a guide for setting azimuth. Rotate the flat part of the ring towards the side that is lower and that side will become lighter causing it to rise. Playing with this will give very accurate azimuth settings.
- Unlike other unipivot arms, the JMW's lateral balance weight does not hang off to the side of the arm. Instead, its position around the bottom of the upper bearing housing places the weight below the pivot point. This increases mass below the pivot and increases arm stability.

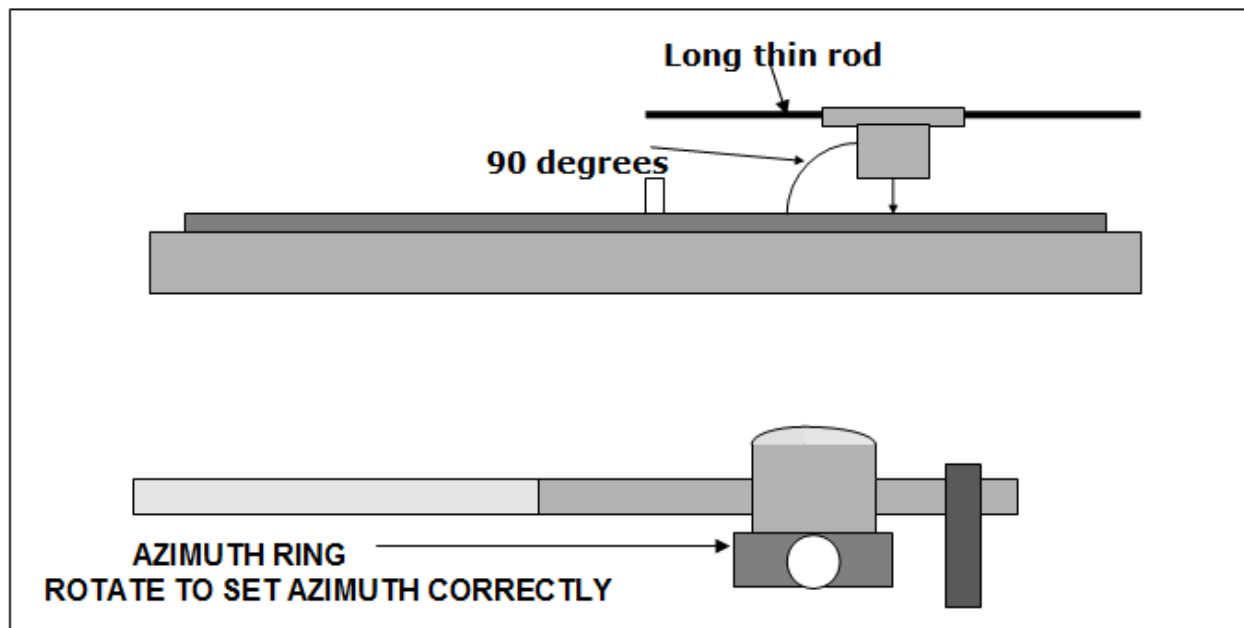

- In the rear of the counterweight stub there is a large hole, in this hole is a screw that is used for fine adjustment of VTF. Use the large wrench supplied for this operation. Most times you will not need this but it is there if you want to really fine tune. You will need a digital tracking force gauge to use this feature properly.

D. ANTI-SKATING:

- Anti-skating is one of the least understood forces acting on a tonearm. Skating force is created by friction between the stylus and the record, causing a force vector in a direction towards the center of the record when the headshell of the tonearm has an offset angle. Putting a stylus down on a flat, grooveless record will cause the arm to move toward the center of the record. Arm manufacturers have tried to compensate

for this force, but that is impossible because the force is constantly changing as the music and velocity change.

- VPI has conducted careful listening tests and determined that every tonearm we tried sounded better with its mechanical anti-skating disabled and the tracking force very slightly increased.

VPI has a unique solution to anti-skating: the coiled wire of the JMW Memorial Tonearm acts as a spring and pushes the arm back without affecting the sound quality.

For those who love to play with test records you now have the option of using a mechanical anti-skate.

If you try adjusting the anti-skate with a groove less record, you will ruin the twist in the tonearm wire and void your warranty. Do this with the mechanical anti-skate if you want not using just the wire.

IF ADDITIONAL ANTI-SKATE IS NEEDED FOR WORKING WITH TEST RECORDS YOU CAN GO TO THE MECHANICAL ANTI-SKATE SUPPLIED. THE THREE RUBBER RINGS SET THE ANTI-SKATE FORCE, THE CLOSER THEY ARE TO THE END OF THE ROD THE MORE ANTI-SKATE FORCE YOU ARE APPLYING.



E. ARM HEIGHT:

- Place a record on the turntable. Loosen the two setscrews in the base of the arm (right side and rear of base). Lower the arm onto the record and make the arm tube parallel to the record surface by rotating the wheel with the 4 prongs sticking out.
- This is a good initial setting. You may wish to vary it depending on the cartridge you are using and or the particular record being played.
- Remember to always retighten those two setscrews when listening. If they are left loose the sound will be unfocused.

F. CABLES

- Use shielded cables for lowest hum and noise.

VPI Industries, Inc. Limited Warranty

VPI Industries, Inc. (VPI) warrants this unit against defects in materials and/or workmanship for three (3) years from the date of purchase by the original retail purchaser. VPI's sole obligation under this warranty is limited to the repair or replacement, at VPI's option, of any part(s) found to be defective. VPI's obligation to repair or replace defective parts is the purchaser's sole and exclusive remedy, and VPI shall not be liable for any direct or indirect injury and/or property damage arising out of the use of the product or defect in or failure of the product.

This warranty does not extend to any unit whose serial number has been defaced or altered. Any product that VPI determines causes a defect or malfunction due to incorrect installation, modification, misuse, or servicing by the purchaser, or service technician not authorized by VPI to perform such service will not be warranted. This warranty does not cover trivial or cosmetic defects that do not impair the unit's normal function.

VPI reserves the right to make changes in this product without assuming any obligation to install such change in any product previously manufactured. This warranty to repair or replace defective parts is in lieu of all other express or implied warranties of merchantability or fitness for a particular purpose. There are not warranties that extend beyond the description herein.

Some states do not allow exclusion of implied warranties or limitation of incidental or consequential damages, so the above exclusion or limitations may not apply to you. This warranty gives you specific legal rights, and you may also have other rights that vary from state to state.

Register your Product Online:

<http://vpiindustries.com/warranty/>

