



The VPI "Traveler" Turntable

Setup and Instruction Manual



VPI Industries, Inc., Cliffwood Ave. #3B, Cliffwood, NJ 07721

<http://vpiindustries.com/>

Important: Read Before Proceeding!

- Read and follow the safety instructions below.
- Save all packing material. The Traveler should only be moved or shipped in its original packaging to reduce the risk of damage in transit.
- The Traveler must be placed on a flat, level surface. This will make setup easy, provide better sound quality and put less strain on the main bearing.

Safety Instructions



Follow the instructions below to reduce the risk of electrical hazard or injury.

- To avoid electrical shock, do not open the motor cover.
- If the supplied power cord does not reach an outlet, use a heavy-duty, grounded extension cord.
- To avoid electrical shock, always plug the Traveler into a grounded outlet.
- Do not expose the Traveler to rain or excessive moisture.

Introduction

The Traveler turntable is a precision instrument. It has been thoroughly tested and run for at least 4 hours before shipment. The speed accuracy, wow, flutter and rumble have been checked and this unit meets all of our specifications.

Minimum Specifications

- Wow and Flutter --- Less than .02%
- Rumble --- Greater than 80db down.
- Speed Accuracy --- Within .1%
- Total Weight --- 24 pounds.
- Platter Run-Out --- Within .003 inch.

Unpacking the Box

The turntable and tonearm have been packed very carefully to avoid damage during shipment. It is important that you save the packing materials and box to use for shipping or moving the Traveler.



Complete and return the warranty card. The warranty does not take effect until the warranty card is returned.

- Remove the tonearm box and gently remove the arm from the packaging place on one of the foam packing layers. **The arm bearings are very sensitive – be careful.**
- Remove additional packing material to uncover the turntable. Carefully remove the turntable by lifting straight up and placing on a flat, sturdy surface that will support its weight. Get assistance in lifting the turntable if needed.
- Remove additional packing material to access the platter. Carefully remove the platter by lifting straight up. Do not damage the platter in any way.

Setting up the Traveler

The Traveler must be placed on a flat, level surface. This will make setup easy, provide better sound quality and put less strain on the main bearing.

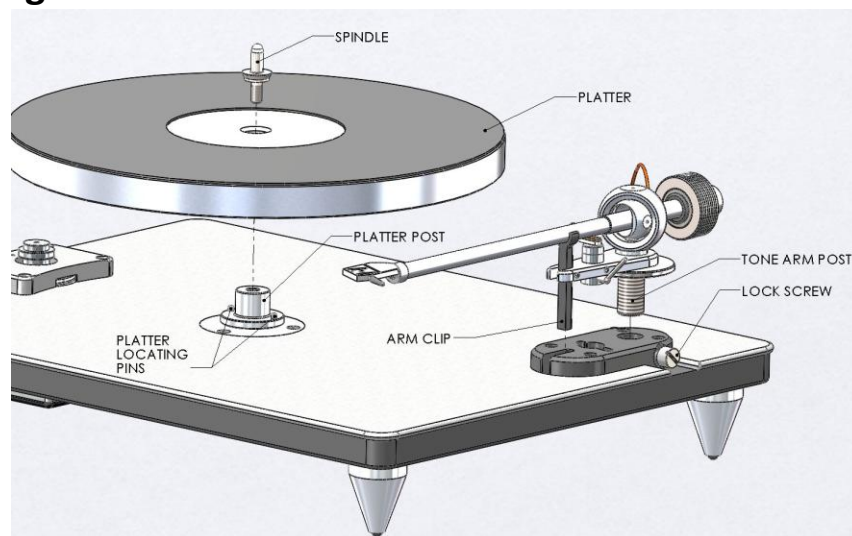

FIGURE 1 (GENERIC PHOTO MAY LOOK DIFFERENT)

- Place the turntable on the shelf or stand where it will be used. The Traveler has built-in isolation so it simply requires a good, solid surface that doesn't sway in the breeze. You can get excellent sound by placing the Traveler on a maple butcher block cutting board about 2" thick.
- The platter bearing has been pre-assembled and lubricated. No additional lubrication should be needed for at least one year.
- Carefully place the Platter on the Platter Post disregard any holes or posts.
- Screw the Spindle through the Platter and into the Platter Post. Using the included spanner wrench, tighten the spindle until snug but not excessively tight. This will center the platter over the bearing and minimize run-out.
- Place the belt around the platter and the pulley. The belt will self level upon rotation. The upper (smaller) pulley diameter is used for 33 1/3 RPM operation and the lower diameter is for 45 RPM.
- Plug the supplied power supply into the rear turntable socket and then plug the power supply into a three prong wall socket.
- If required, level the turntable by using a 9 or 12 inch bubble level placed on the base, in front of the platter to adjust left/right and on the side for front/back level. Move the level and re-adjust as needed until the turntable is level in both directions. Rotate the feet up or down as needed. If more than three turns are needed, level the shelf or platform holding the table first.
- Loosen the Lock Screw and insert the Tonearm assembly so that the Tonearm Post and the Arm Clip align with the openings in the base as shown in the illustration above.

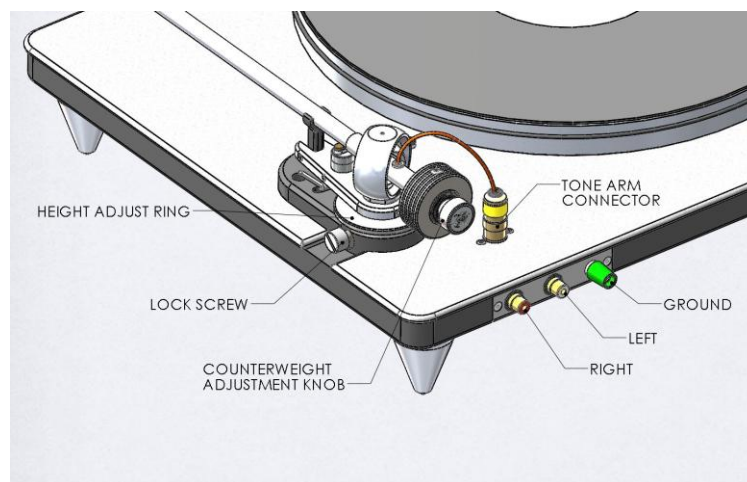

FIGURE 2

BEFORE YOU BEGIN

NOT FOLLOWING THIS MANUAL WILL VOID YOUR WARRANTY.
FAILURE TO SEND IN THE WARRANTY CARD WILL VOID YOUR WARRANTY.

- Be very careful when handling the tone arm. The internal arm wire is exposed at the headshell and at the rear of the arm. This wire is *very* delicate. Physical damage to the wire is not covered by the warranty after the arm is removed from its box.
- There are a number of setscrews on the Traveler tonearm. The Allen wrenches that come with your arm will only fit the setscrews that you will need to adjust. All other screws are factory set and should not be adjusted, except by our trained technicians. Resetting any of the factory settings is not covered by the warranty.

A. CARTRIDGE MOUNTING:

- FOR CARTRIDGES WITH THREADED MOUNTING HOLES use the screws supplied by the cartridge manufacturer to mount the cartridge. Any other screws may not fit the thread properly and may even damage the threads and cartridge. USE ONE OF THE SUPPLIED WASHERS UNDER THE SCREW HEAD.
- For all cartridges with pass through mounting holes use the hardware supplied with the arm. Remember to use the washers under the screw heads to prevent damage to the finish on the Traveler arm. In this step, the connectors will be attached to the cartridge's terminals. Disregard the color of the insulators on the cartridge clips.

THE COLOR CODE OF THE WIRES IS AS FOLLOWS:

RED = right hot	WHITE = left hot
GREEN = right ground	BLUE = left ground

IF YOUR PHONO SECTION INVERTS PHASE, THE HOT BECOMES
THE GROUND COLOR

- Using tweezers or fine tipped pliers, grip the center of the red wire's connector (do not grip the wire) and push it onto the cartridge's right hot terminal pin. In the same way, connect each of the remaining connectors to its respective cartridge terminal. Do not push the connectors all the way on, as this could damage the cartridge. Always back up the cartridge with your finger when pushing on the clips.

B. THE COUNTERWEIGHT:

- The Traveler tone arm comes with the counterweight installed on the rear shaft of the tonearm. For most cartridges you will only need this large weight. The counterweight moves on the shaft with the thumbscrew in the rear of the arm. This is a fine adjustment and will give you very accurate results.

C. BALANCING ARM: TRACKING FORCE AND AZIMUTH

- Plug the arm wire connector into its receptacle at the rear of the Traveler base. Notice that the connector can plug in only one way. Push gently, do not force the plug.

- Depending on the twist given to the wire when the plug was inserted into the box, the arm will have a tendency to swing inward or outward when it is in neutral horizontal balance. Later on, you will adjust the wire's twist to provide slight anti-skating compensation.
- Move the counterweight until the arm has a very slight downward tracking force, just enough to keep it from moving sideways on the platter or enough to keep it in the groove of the record

D. TRACKING FORCE:

- Tracking force is adjusted by moving the counterweight forward and back just a bit at a time. At least initially, you will be setting the tracking force twice. The first time will be before the cartridge's overhang is set. After this is done, you will need to double check the tracking force and adjust it as needed.
- The Traveler does not have a built-in tracking force gauge. If using a gauge, use the instructions to set the tracking force to the cartridge manufacturer recommendation plus 1/10 of a gram more. We always recommend going to the high side when it comes to tracking force. High frequency vibrations can cause a light tracking cartridge to cause more damage to the grooves than running a cartridge at a heavy setting. Make sure the damping fluid is not installed when setting this force.
- Always make sure that the arm is parallel to the platter when on the gauge and then parallel to the platter when on the record. By doing that you will actually be tracking at the force you set with the gauge. You can vary the vertical height later using the large thumbwheel but for now parallel is king.

E. OVERHANG ADJUSTMENT: TONEARM DETAILS

Pivot to spindle – 235 mm

Overhang – 16 mm

Effective length – 251 mm

Offset angle – 21.82 degrees

Inner null point – 66 mm

Outer null point – 121 mm

- This adjustment will yield the lowest overall distortion when playing a typical 12" record. Do not go crazy over this adjustment. You do not know if the stylus is aligned properly on the cantilever. You are also facing a constantly moving target when playing a record. The arm is moving in 3-dimensions and will only approximate the accuracy you have built into your alignment.
- Place the Traveler Alignment Jig into position and make sure that the jig's cutout fits against and around the arm rest.
- While the arm is in its rest, loosen the screws that hold the cartridge just enough that the cartridge can be moved back and forth and side to side.
- Carefully swing the arm over the grid at the far end of the jig and place the stylus as close to the dot in the center of the grid as possible. Using a lighted magnifier or new magnified glasses with lights will make this job very easy.

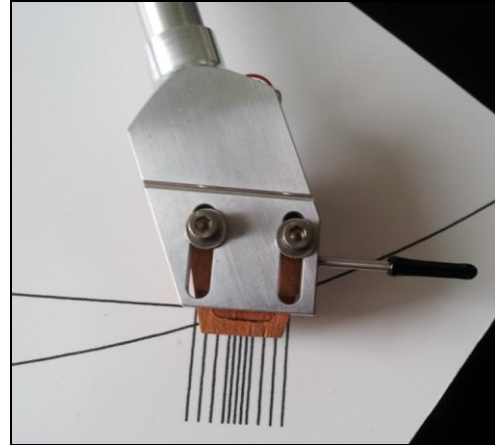
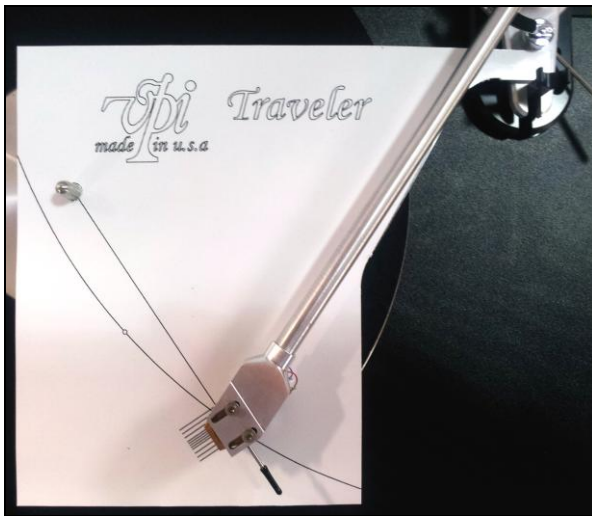

BE VERY CAREFUL NOT TO DAMAGE THE CARTRIDGE'S STYLUS:

- Move the cartridge so that the stylus rests on the dot. Now, viewing the cartridge from above, line it up so that its sides are symmetrically positioned between the lines of the grid. If the cartridge has parallel sides, these should be made parallel to the grid lines. Also make sure that the cartridge is centered between the sets of lines.
- Double check the adjustments made above. The cartridge needs to be both centered and "square" between the grid lines and have the stylus resting on the dot.

LOOK DOWN THE STYLUS CANTILEVER FROM THE FRONT OF THE CARTRIDGE AND SEE IF IT IS LINED UP WITH THE GRID

- The alignment gauge does not have a hole or dimple to hold the stylus. While the printed dot makes it harder to keep the stylus in place, this method was chosen to avoid the possibility of damaging the stylus cantilever or the diamond tip as the cartridge is positioned.
- Place the arm back in its rest.
- Without letting the cartridge move, tighten the screws holding the cartridge to the arm head. Make it tight, but don't over-do it and strip the threads or distort the cartridge body.
 - Double check the tracking force and adjust as needed. Increase the tracking force by 1/10 of a gram above the cartridge manufacturer's highest recommended force.

F. ANTI-SKATING:

- Anti-skating is one of the least understood forces acting on a tonearm. Skating force is created by friction between the stylus and the record, causing a force vector in a direction towards the center of the record when the headshell of the tonearm has an offset angle. Putting a stylus down on a flat, groove less record will cause the arm to move toward the center of the record. Arm manufacturers have tried to compensate for this force, but that is impossible because the force is constantly changing as the music and velocity change.

G. ARM HEIGHT:

- To adjust the arm height, loosen the THUMBSCREW on the base of the arm assembly and turn the adjustment wheel above the base. Put a record on the platter and a 5X7 lined index card (bent in half on the middle line) on the record near the spindle. Use the lines on the card as a starting point to adjust arm height. Make the arm tube parallel to the lines on the card. When the arm is at the desired height, tighten the screw. You can raise or lower the arm later for fine adjustments.

H. CONNECTING TO THE PREAMPLIFIER/AMPLIFIER

- ONLY USE INTERCONNECTS THAT ARE SHIELDED AND PROPERLY GROUNDED. NON-SHIELDED INTERCONNECTS CAN HUM AND PICK UP RF.
- The ground connection is available to eliminate hum if necessary. If hum is present, first connect a ground lead from the connector block to the preamplifier or amplifier to which the output cable is connected. If this does not eliminate the hum, run a ground wire from the turntable chassis to the connector block as well. The block's connector will accept bare wires, spade lugs, or ring tongue connectors,

VPI Industries, Inc. Limited Warranty

VPI Industries, Inc. (VPI) warrants this unit against defects in materials and/or workmanship for three (3) years from the date of purchase by the original retail purchaser. VPI's sole obligation under this warranty is limited to the repair or replacement, at VPI's option, of any part(s) found to be defective. VPI's obligation to repair or replace defective parts is the purchaser's sole and exclusive remedy, and VPI shall not be liable for any direct or indirect injury and/or property damage arising out of the use of the product or defect in or failure of the product.

This warranty does not extend to any unit whose serial number has been defaced or altered. Any product that VPI determines causes a defect or malfunction due to incorrect installation, modification, misuse, or servicing by the purchaser, or service technician not authorized by VPI to perform such service will not be warranted. This warranty does not cover trivial or cosmetic defects that do not impair the unit's normal function.

VPI reserves the right to make changes in this product without assuming any obligation to install such change in any product previously manufactured. This warranty to repair or replace defective parts is in lieu of all other express or implied warranties of merchantability or fitness for a particular purpose. There are not warranties that extend beyond the description herein.

Some states do not allow exclusion of implied warranties or limitation of incidental or consequential damages, so the above exclusion or limitations may not apply to you. This warranty gives you specific legal rights, and you may also have other rights that vary from state to state.

Register your Product Online:

<http://vpiindustries.com/warranty/>

