

**SETUP MANUAL FOR THE  
ARIES 3 TURNTABLE WITH  
CLASSIC 3 ARM**

***READ THIS MANUAL VERY CAREFULLY***

***NOT FOLLOWING THIS MANUAL WILL VOID YOUR  
WARRANTEE***

VPI INDUSTRIES INC., 77 CLIFFWOOD AVE #3B,  
CLIFFWOOD NJ 07721  
[www.vpiindustries.com](http://www.vpiindustries.com)

- **THE MOST IMPORTANT THING YOU CAN DO FOR YOUR NEW ARIES-3 TURNTABLE IS TO PLACE IT ON A FLAT LEVEL SURFACE. IT CANNOT BE STRESSED ENOUGH THAT A FLAT SURFACE WILL MAKE SETTING UP YOUR NEW ARIES A SNAP.**
- **THE STANDARD ARIES-3 REQUIRES A SPACE OF 22" X 16" FOR ITS MAIN FRAME. THE ACTUAL FOOTPRINT OF THE ARIES-3 LEGS MEASURES 19" X 13"**

## **SPECIFICATIONS**

YOUR NEW ARIES-3 TURNTABLE IS A PRECISION INSTRUMENT. IT HAS BEEN THOROUGHLY TESTED AND HAS BEEN RUN FOR AT LEAST TWO HOURS. THE SPEED ACCURACY, WOW, FLUTTER, AND RUMBLE HAVE BEEN CHECKED AND THIS UNIT HAS MET ALL OUR SPECIFICATIONS.

MINIMUM SPECIFICATIONS: WOW AND FLUTTER – LESS THAN .02  
 RUMBLE – GREATER THAN 80 db DOWN  
 SPEED ACCURACY – WITHIN .1%  
 TOTAL WEIGHT – 60 POUNDS  
 PLATTER RUNOUT - +/- .001 INCH

## **INSTRUCTIONS FOR UNPACKING AND SETUP**

- If you are reading this manual, you must have opened up the main turntable box. In this box you will find the main ARIES-3 chassis, tonearm, and all tools needed. Remove all packaging, noting how it fits together. If you ever need to send the Aries 3 back for service you must pack it properly. Save the packaging if you can, it will be very expensive to order it later.
- If you ordered the JMW-10.5i Memorial tonearm with your ARIES-3, the tonearm is packed in this box and should be removed carefully. The base of the tonearm is mounted directly to the ARIES-3 Solid Delrin tonearm board, follow the directions for the JMW-10.5i Memorial tonearm and carefully set up the cartridge.
- If you ordered the ARIES-3 cut for another tonearm, follow the tonearm manufacturer's recommendations for proper setup. Remember that cartridge setup is a complicated but satisfying endeavor. If you take your

time and protect the stylus you will ultimately be rewarded with a good sounding unit that you will not be afraid of working on.

- Before lifting out the main chassis, remember that the feet are attached to the bottom of the unit. Do not put the unit down on any furniture that could be damaged by these feet. Remove the protective bag and set the ARIES-3 chassis down and center it on the shelf it will be resting on.
- Lift out the platter and pull off the tape covering the spindle hole. Carefully place the platter over the spindle and let it slide down. The platter bearing has grease in it so none is needed at this time. The ARIES-3 needs no lubrication for at least one year. A Chrome hardened ball running on a large Teflon surface takes the weight of the platter. This requires no lubrication to perform its task.
- Spin the platter and see if it feels like it is running freely. If all is okay and the platter feels free but not loose proceed to the motor.
- Open the 12X12X12 box and place the motor in the circular cutout to the left of the ARIES-3 chassis with the switch facing left. Center the motor in this cutout with roughly a 1/2" space between it and the chassis all the way around. The motor needs no lubrication at this time and should be relatively noise free. It was just shipped and will be much quieter after a few hours running.
- Remove the drive belt from the bag and place the belt on the small pulley groove and around the turntable platter. The drive pulley is designed for 33 and 45 operation with the smaller section being 33 and the larger section being 45. The motor pulley of your ARIES 3 is designed to let you slightly adjust the speed at 33 and 45. The center groove on the pulley in each diameter is the correct speed. If you need to increase or decrease the speed slightly you can move the belt up or down for fine adjustment. Most people will just leave it on the center groove and never worry about it. If you hear any noise when starting the turntable put baby powder on the drive belts.

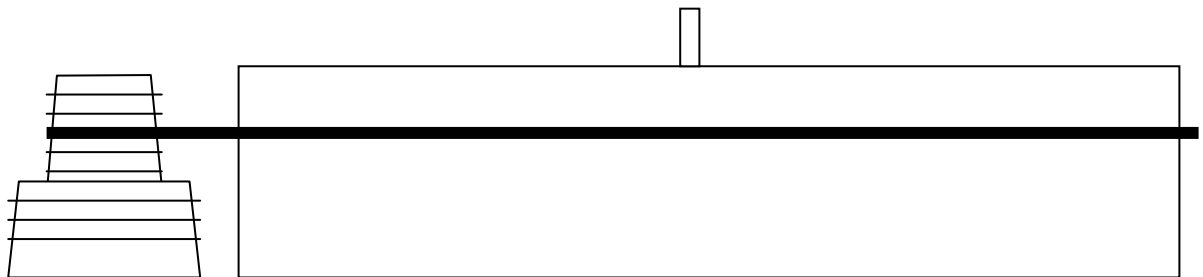

- Level the turntable using a 9” or 12” long bubble line level placed next to the spindle on the platter. The feet rotate in their sockets and will move up and down allowing fine leveling of the ARIES-3. A level turntable will always sound better than an unlevelled one and will put less strain on the main bearing.
- If you need to remove the armboard you should use the 9/64” Allen wrench supplied.

## THE CLASSIC 3 TONEARM

- A NEW BASE HAS BEEN DESIGNED FOR YOUR TONEARM. IT WILL SUPPORT THE ARM AT THE VTA TOWER AND AT THE CUEING MECHANISM. THIS SUPPORT GIVES THE ARM MUCH GREATER RIGIDITY AND PROVIDES DEEPER TIGHTER BASS RESPONSE.
- THE ARMS NOW HAVE THUMBSCREWS INSTEAD OF SET SCREWS FOR EASIER SETUP AND ADJUSTMENT OF VERTICAL TRACKING ANGLE (VTA, SRA)

### **BEFORE YOU BEGIN**

NOT FOLLOWING THIS MANUAL WILL VOID YOUR WARRANTY.  
FAILURE TO SEND IN THE WARRANTY CARD WILL VOID YOUR WARRANTY.

- Be very careful when handling the tone arm. The internal arm wire is exposed at the headshell and at the rear of the arm. The Nordost Valhalla wire is *very* delicate and physical damage to the wire is not covered by the warranty after the arm is removed from its box.
- Please do not touch the unipivot bearing parts. Finger oils on the bearing cup in the upper bearing housing or on the lower pivot point in the arm base assembly can cause blemishing of the bearing and possible corrosion. Also, the point is sharp, be careful.
- There are a number of setscrews on the Classic 3 Tone Arm. The Allen wrenches that come with your arm will only fit the setscrews that you will need to adjust. All other screws are factory set and should not be adjusted, except by our trained technicians. Resetting any of the factory settings is not covered by the warranty.

## UNPACKING YOUR JMW MEMORIAL TONE ARM

- This instruction manual was lying on a large foam pad. Remove the pad and put it nearby on your work surface.
- You will now see a number of things in plastic bags:
  - Allen wrenches for cartridge mounting and fine VTF adjustment
  - Hex nuts, and washers (for cartridge mounting)
  - Arm mounting and alignment tool
  - Damping fluid
- Take all these items out and set them aside. Be careful with the damping fluid. It should be kept sealed until it is used.
- You can now see the arm tube and counterweight, with its delicate Valhalla wire and Lemo connector, and the arm base assembly. If your arm is pre-mounted on a tone arm board, remove the small foam piece covering the "front" of the arm board. Set it aside with the other packing material.
- Now, here's the hard part. Leave the arm tube and arm base assembly where they are -- safe in their packaging.

### **A. CARTRIDGE MOUNTING:**

- Remove the arm tube from the box (taking special care not to strain or damage, the delicate 4-color wire and Lemo connector) and place it right side up on the foam pad.

#### FOR CARTRIDGES WITH THREADED MOUNTING HOLES:

- Use the screws supplied by the cartridge manufacturer to mount the cartridge. Any other screws may not fit the thread properly and may even damage the threads and cartridge. **USE ONE OF THE SUPPLIED WASHERS UNDER THE SCREW HEAD.**
- For all cartridges with pass through mounting holes use the hardware supplied with the arm. Remember to use the washers under the screw heads to prevent damage to the finish on the JMW arm. In this step, the connectors will be attached to the cartridge's terminals. Disregard the color of the insulators on the cartridge clips.

#### THE COLOR CODE OF THE WIRES IS AS FOLLOWS:

RED = right hot  
GREEN = right ground

BLACK OR WHITE = left hot  
BLUE = left ground

## IF YOUR PHONO SECTION INVERTS PHASE, THE HOT BECOMES THE GROUND COLOR

- The arm tube should be on its side on the foam pad when doing this.
- Using tweezers or fine tipped pliers grip the center of the red wire's connector (do not grip the wire) and push it onto the cartridge's right hot terminal pin. In the same way, connect each of the remaining connectors to its respective cartridge terminal. Do not push the connectors all the way on, as this could damage the cartridge. Always back up the cartridge with your finger when pushing on the clips.
- The Classic 3 tone arm comes with one large dropped counterweight installed on the rear shaft of the tonearm. For most cartridges you will only need this large weight. The counterweight is held in position by a setscrew.
- Pick up the arm tube, taking care not to strain or damage the fine 4-color wire and Lemo connector.
- For now, position the large counterweight as close to the bearing housing as you can (toward the front of the arm) but not touching the balance ring. The object here is to balance the arm while keeping the counterweight as close to the bearing housing as possible. This results in the least inertia for a given cartridge weight.
- In some rare cases it may be necessary to use two counterweights together or a larger counterweight. Contact your dealer if a second or larger counterweight is needed.

## **B. TRACKING FORCE AND AZIMUTH**

- Place the arm tube assembly on the lower bearing, taking care not to strain or damage the 4-color wire and Lemo connector. Place the arm in its rest.
- At the rear of the arm base assembly is the connector block. Plug the Lemo connector into its receptacle on top of the block. Notice that the connector can plug in only one way. Align the red dots on the arms plug with the red dot on the receptacle. Push gently, do not force the plug.
- Make sure the turntable is level. Refer to your turntable instructions and use a bubble level to check level. In most cases, the best place to put the level is on the platter.

***With a unipivot arm it is particularly important to level the turntable.***

- Move the counterweight until the arm has a very slight downward tracking force, just enough to keep it from moving sideways on the platter or enough to keep it in the groove of the record
- Next, the lateral balance or azimuth must be set. Because the phono cartridge is offset, there is an unbalancing force that tilts the arm to one side. For the cartridge to properly track the record groove, the stylus must be ninety degrees to the record surface. Move the counterweight so a slight tracking force is applied and the stylus just sits on the record surface.
- Rotate the counterweight as needed to bring the arm into correct lateral balance to set azimuth. When the azimuth has been set, you can lightly tighten the setscrew located on the top of the counterweight. You can use the azimuth ring or the counterweight to set correct azimuth. Lay the long thin rod supplied behind the cartridge mounting screws into the V groove and use it as a guide for setting azimuth.

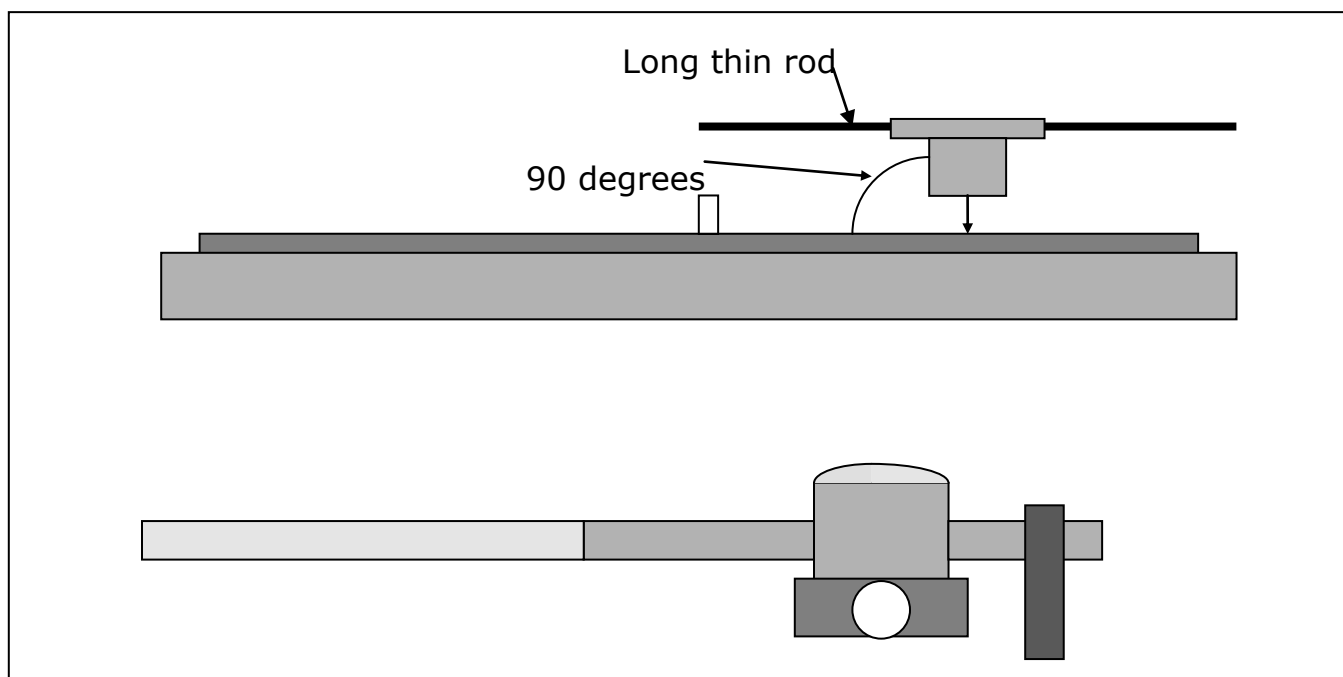

- Unlike other unipivot arms, the Classic 3's lateral balance weight does not hang off to the side of the arm. Instead, its position around the bottom of the upper bearing housing places the weight below the pivot point. This increases mass below the pivot and increases arm stability.

## **C. TRACKING FORCE (VTF):**

- Tracking force is adjusted by moving the counterweight forward and back just a bit at a time. At least initially, you will be setting the tracking force twice. The first time will be before the cartridge's overhang is set. After this is done, you will need to double check the tracking force and adjust it as needed.
- The Classic 3 does not have a built-in tracking force gauge, but a Shure Stylus Force Gauge is supplied with your arm on a new unit. Following the gauge instructions set the tracking force to the cartridge manufacturer recommendation plus 1/10 of a gram more. We always recommend going to the high side when it comes to tracking force. High frequency vibrations can cause a light-tracking cartridge to cause more damage to the grooves than running a cartridge at a heavy setting. Make sure the damping fluid is not installed when setting this force.

**VERY IMPORTANT: MAKE SURE THE TONEARM IS PARALLEL TO THE PLATTER WHEN SETTING THE TRACKING FORCE. IF IT IS NOT THE END RESULT WILL BE HIGHER OR LOWER VTF THAN YOU WANTED.**

- In the rear of the counterweight stub there is a large hole, in this hole is a screw that is used for fine adjustment of VTF. Use the large wrench supplied for this operation. Most times you will not need this but it is there if you want to really fine tune. You will need a digital tracking force gauge to use this feature properly.

## **D. ANTI-SKATING:**

*REMEMBER: A 10.5" ARM NEEDS VERY LITTLE ANTI-SKATING FORCE*

- Anti-skating is one of the least understood forces acting on a tonearm. Skating force is created by friction between the stylus and the record, causing a force vector in a direction towards the center of the record when the headshell of the tonearm has an offset angle. Putting a stylus down on a flat, groove less record will cause the arm to move toward the center of the record. Arm manufacturers have tried to compensate for this force, but that is impossible because the force is constantly changing as the music and velocity change.
- VPI has conducted careful listening tests and determined that every tonearm we tried sounded better with its mechanical anti-skating disabled and the tracking force very slightly increased.

VPI has a unique solution to anti-skating: the coiled wire of the JMW Memorial Tonearm acts as a spring and pushes the arm back without



affecting the sound quality. You now have the option of installing a mechanical anti-skate for those that want it.

- Adjust the counterweight so there is no down force on the cartridge.
- Swing the tonearm toward the spindle and release it. The arm should swing out toward the outer edge of the turntable.



If you try adjusting the anti-skate with a groove less record, you will ruin the twist in the tonearm wire and void your warranty. Do this with the mechanical anti-skate if you want that much anti-skate.

- IF ADDITIONAL ANTI-SKATE IS NEEDED FOR WORKING WITH TEST RECORDS YOU CAN GO TO THE MECHANICAL ANTI-SKATE SUPPLIED.



## **E. OVERHANG ADJUSTMENT: (FIG. 2)**

- This adjustment will yield the lowest distortion in the last third of the record, the hardest to track, when playing a typical 12" record. Do not go crazy over this adjustment. You do not know if the stylus is aligned properly on the cantilever. You are also facing a constantly moving target when playing a record. The arm is moving in 3-dimensions and will only approximate the accuracy you have built into your alignment.
- Place the Alignment Jig into position by sliding the narrow end with the circular cutout between the arms lateral balance weight and the platform that supports the armrest. Make sure that the jig's cutout fits against and around the bearing well.

- While holding the one end against the bearing well, swing the other end (with the hole) over the turntable's spindle so that the spindle holds the jig in place. Check figure 1 on the last page.
- While the arm is in its rest, loosen the screws that hold the cartridge just enough that the cartridge can be moved back and forth.
- Carefully swing the arm over the grid at the far end of the jig and place the stylus as close to the dot in the center of the grid as possible. Using a lighted magnifier will make this job very easy.

#### BE VERY CAREFUL NOT TO DAMAGE THE CARTRIDGE'S STYLUS:

- Move the cartridge so that the stylus rests on the dot. Now, viewing the cartridge from above, line it up so that its sides are symmetrically positioned between the lines of the grid. If the cartridge has parallel sides, these should be made parallel to the grid lines. Also make sure that the cartridge is centered between the sets of lines. Follow figure 2 in the back of the manual. If you can see the cantilever clearly you can align the cantilever to the alignment grid. This is difficult and may produce no increase in sound quality.
- Double check the adjustments made above. The cartridge needs to be both centered and "square" between the grid lines and have the stylus resting on the dot.
- The alignment gauge does not have a hole or dimple to hold the stylus. While the printed dot makes it harder to keep the stylus in place, this method was chosen to avoid the possibility of damaging the stylus cantilever or the diamond tip as the cartridge is positioned.
- Place the arm back in its rest.
- Without letting the cartridge move, tighten the screws holding the cartridge to the arm head. Make it tight, but don't over do it and strip the threads or distort the cartridge body.
- Double check the lateral balance and tracking force and adjust as needed. Increase the tracking force by 1/10 of a gram above the cartridge manufacturer's highest recommended force.

#### **F. ARM HEIGHT:**

Unlike many tone arms, the JMW's height is both easy and repeatable to vary. The knob next to the bearing housing bears a scale numbered from zero to ninety-nine. Below the knob there is an index mark engraved on the front of the support pillar.

Rotating the knob clockwise lowers the arm and rotating it counterclockwise raises it.

Set the arm height as follows:

- Start the turntable and place a record on it. Lower the arm onto the record and make the arm tube parallel to the record surface by rotating the arm-height knob as needed.
- This is a good initial setting. You may wish to vary it depending on the cartridge you are using and or the particular record being played. The knob's scale makes it easy to return to a previous setting by making a note of the number above the index mark and the number of complete turns taken.
- The old wisdom, which had the arm tube parallel to the record surface, assumed not only that all cartridges had the same internal geometry and stylus rake angle but also that all records were cut with the same equipment set the same way. The idea was that everything would line up properly with the arm parallel to the record.
- If you have a gentle touch (so as not to bounce the turntable) you can simply vary the arm height while listening to the record and the changes in distortion those results. Depending upon your patience and other mental factors, you could go through this process for every record you own. Or, as most of us do, you can find a setting that works for most records and sit back and listen to the music.

**THE ARM HAS TWO BLACK THUMBSCREWS FOR LOCKING THE VTA SETTING ONCE YOU ARE DONE ADJUSTING. LOCKING THE ARM WILL GIVE THE BEST SOUND WITH THE TIGHTEST CLEANEST BASS. REMEMBER, WHEN MOVING THE VTA UP OR DOWN YOU MUST LOOSEN BOTH THUMBSCREWS**

- You can now add damping fluid. Use only enough to stabilize the arm, too much will kill the sound and make the cartridge sound slow. Try listening with and without damping and decide which you like better in your system and with your cartridge.

## **G. CONNECTING TO THE PREAMPLIFIER/AMPLIFIER**

- ONLY USE INTERCONNECTS THAT ARE SHIELDED AND PROPERLY GROUNDED. NON-SHIELDED INTERCONNECTS CAN HUM AND PICK UP RF.
- The ground connection is available to eliminate hum if necessary. If hum is present, first connect a ground lead from the connector block to the preamplifier or amplifier to which the output cable is connected. If this does not eliminate the hum, run a ground wire from the turntable chassis to the connector block as well. The block's connector will accept bare wires, spade lugs, or ring tongue connectors.
- 



***FIG. #1: THE PROPER WAY TO USE THE ALIGNMENT JIG. THE PICTURE SHOWS A 12.6 BEARING, THE ADJUSTMENT IS THE SAME.***

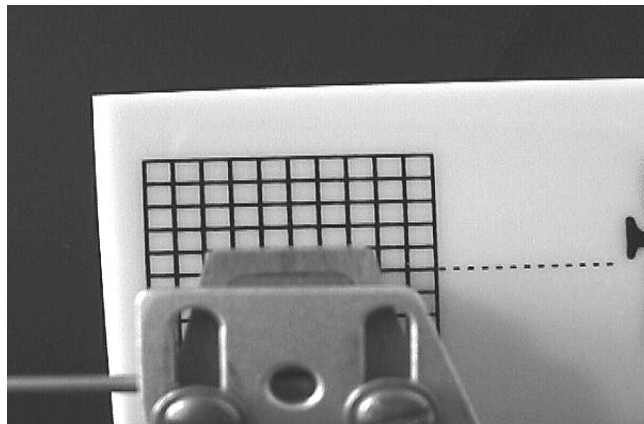

***FIG #2: THE PROPER WAY TO ALIGN A CARTRIDGE, ALIGN THE CARTRIDGE, NOT THE TONEARM HEADSHELL!***

# WARRANTY

## VPI INDUSTRIES, INC. LIMITED WARRANTY OF THE ARIES TURNTABLE

VPI Industries, Inc. (VPI) warrants this unit against defects in materials and/or workmanship for three (3) years from the date of purchase by the original retail purchaser. VPI's sole obligation under this warranty is limited to the repair or replacement, at VPI's option, of any part(s) found to be defective. VPI's obligation to repair or replace defective parts is the purchaser's sole and exclusive remedy, and VPI shall not be liable for any direct or indirect injury and/or property damage arising out of the use of the product or defect in or failure of the product.

This warranty does not extend to any unit whose serial number has been defaced or altered. Any product that VPI determines contains a defect or malfunction due to incorrect installation, modification, misuse, or servicing by the purchaser, or service technician not authorized by VPI to perform such service will not be warranted. This warrantee does not cover trivial or cosmetic defects that do not impair the unit's normal function.

VPI reserves the right to make changes in this product without assuming any obligation to install such change in any product previously manufactured. This warranty to repair or replace defective parts is in lieu of all other express or implied warranties of merchantability or fitness for a particular purpose. There are no warranties that extend beyond the description herein.

Some states do not allow exclusion of implied warranties or limitation of incidental or consequential damages, so the above exclusion or limitations may not apply to you. This warranty gives you specific legal rights, and you may also have other rights that vary from state to state.

Register your Product Online:

<http://vpiindustries.com/warranty/>

