

HOW TO SET UP YOUR TNT 3

- The most important thing you can do for your new TNT 3 is to place it on a level surface. It cannot be stressed enough, that a level base for the TNT will make set up a snap.
- It is best to place the TNT 3 on a level surface that measures at least 27x21 inches. This will allow room for the optional dust cover if you should want to purchase it.
- Open box labeled PART B. Remove the foam and you will find the Pulley Drive Unit or PDU, and the Motor Drive Unit or MDU. You will notice that under the round foam cutout is the platter. Remove it and place it in a safe location.
- In the box labeled PART A you will find four clear zip lock bags labeled "Right Front", "Left Rear", etc. Remove these four bags with the parts enclosed. These four parts are the feet of the TNT 3. You will notice that not only are the units labeled but they also have notches cut in their cylindrical shape. Place the feet in their respective corners on the turntable stand following the labeling. The notch should face the center of the turntable as shown below.

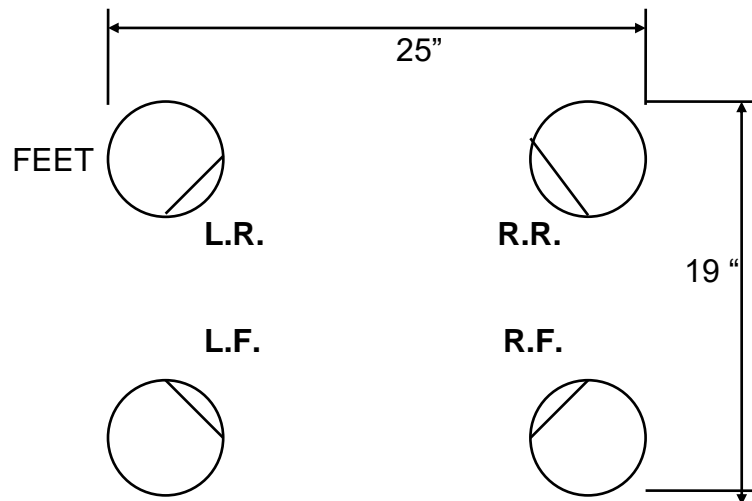

- Now is the time to peel the protective paper from the PDU. With the feet properly placed as shown you can now put the pulley drive unit (triangular shape) on the stand. The corner with the side cut off goes on the left side as shown below.

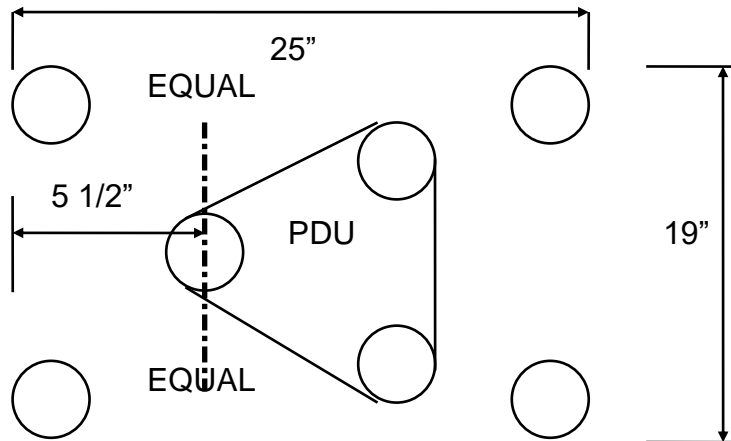

- Make sure that the dimensions given are exactly what you have in your setup. If you place these 5 items properly, the main chassis will drop over them with no problem. It is recommended that a second person be around to help, just in case something happens while you are lining everything up.
- Go back to the box labeled PART A, you will now see the Main Chassis. Carefully lift out the Main Chassis and remove the plastic bag. This would be the proper time to remove the protective covering from the bottom of the Main Chassis.
- Notice that the stainless steel cups in the corners of the Main Chassis have foam in them. The foam is there to damp motion and keep the spring feet centered. Lift the main chassis and position it above the 4 feet and PDU. Carefully lower the Main Chassis so that it slips over the feet and the pulleys slip through the holes drilled for them.
- You should now have the Main Chassis sitting on the 4 feet and the pulleys not touching anything. This is a good time to make sure that the table is positioned the way you want it. If it must be moved slightly or centered on its stand, do it slowly. You should also be certain that the flat spot in the cylindrical leg has not changed position. Peel off the paper on the top of the main chassis.
- If everything is okay, you can place the platter on the spindle. You will notice that there is a dot on the spindle flange and the underside of the platter. It is not that critical, but the two dots should line up as closely as possible. Carefully lower the platter down onto the spindle flange. Spin the platter and see that it is spinning freely and that there is no wobble.

- This is a good time to level the turntable. It is very important that the platter be level. Place a good 12" long bubble level across the platter avoiding the three screw holes. Make two settings with the level 90 degrees rotated per setting. Adjust the set screws in the 4 stainless steel corner cups, using the wrench provided, until the unit is level. Try to get the stainless steel cups 2 ½ " up from the surface the table is sitting on.
- You can now place the Motor Drive Unit (MDU) in position. You will notice that the left side of the TNT 3 has a cut out where the motor and drive pulley is positioned. The drive pulley is already in position and now the MDU must be placed next to it in the position shown below.

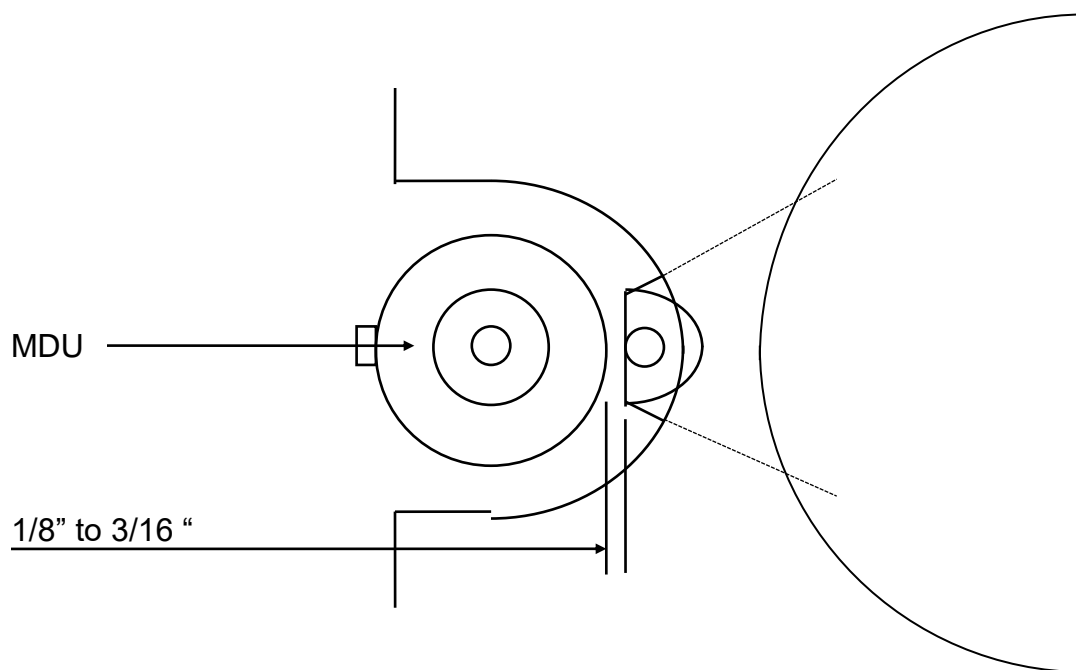

- **12-** Place the belts on the pulleys as shown below for 33 RPM use.

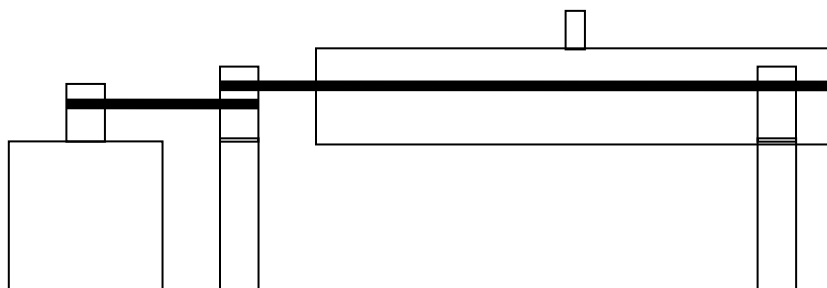

- If the belt does not run perfectly level between the platter and the three pulleys you should readjust the corner leveling screws. If you turn them all one turn at a time you will not change the level of the TNT, but you will move the entire unit up and down.
- Plug the grounded line cord from the MDU into the grounded outlet in the PLC drive unit. **For safety sake do not remove the ground.** Put the strobe disc on the platter and using the controls of the PLC set the speed at 33 and 45 so the lines on the strobe do not move clockwise or counterclockwise.
- Mount the tonearm as stated in the JMW manual and allow the unit to run for one hour to loosen up. Re-check the level after installing the tonearm.
- There is very little maintenance associated with the TNT 3. Every 3 months re-powder the two drive belts by placing them back in the bags they came in. Shake off the excess powder and put them back in the same location on the pulleys.
- The bottle of light oil is used to occasionally lubricate the drive pulleys and the motor. If a pulley ever makes noise it is time to re-lube it.
- You can expect a break-in period of at least 30 hours before the TNT will sound its' best.
- When playing records remember that the black washer goes on the platter first, then the record, than the clamp. This system will force the air out from under the record and form a partial vacuum. You will notice when you release the clamp the record does not pop back up. If done properly you will get most of the effect of vacuum with none of the problems or complications.
- It is perfectly normal for the motor to make some low-level noise. None of this gets into the system and will eventually reach a very low level. The more you use your TNT the quieter the motor and the bearings will become.
- You must mail in your warrantee card. If your card is not received within 30 days of purchase you are jeopardizing your warrantee. The motor and bearings of the TNT 3 are warranted for 2 years. There is nothing else that can fail on your TNT except the belts, which should be changed every year.

LIST OF PARTS IN BOXES

1 - BOX A:

- 4 Legs
- PLC
- Main Chassis
- Instruction Manual Kit containing:
 1. Instruction manual
 2. Allen wrench for armboard screws
 3. 2 drive belts
 4. Light pulley lubricating oil
 5. Record Clamp and washer

2- BOX B:

- Motor Drive Unit
- Pulley Drive Unit
- Platter